

REV	REVISION	DRAWN BY	APPROVAL	DATE
01	INITIAL MANUFACTURING RELEASE	AJC	AJC	01/09/14

ITEM	PART NUMBER	REV	DESCRIPTION	DESCRIPTION 2	Qty
1	10014		COMPRESSOR,AC,300VDC		1
2	20253-01		HARNESS,AC,COMP,HVIL,POTTED	POTTED HARNESS ON AC COMPRESSO	1
3	20270-00		HARNESS,AC COMP,TEMP	AC COMP SUB ASSEMBLY TEMP HARN	1
4	60021-00		RTV,WHITE,ELECTRICAL GRADE	MOMENTIVE PERFORMANCE MATERIAL	40 ml
5	30085		WASHER,FLAT,#10	ZPS	1
6	30160		WASHER,LOCK,#10	ZPS	1
7	30163		BOLT,HEX HEAD,#10-24X0.5"L	ZPS	1

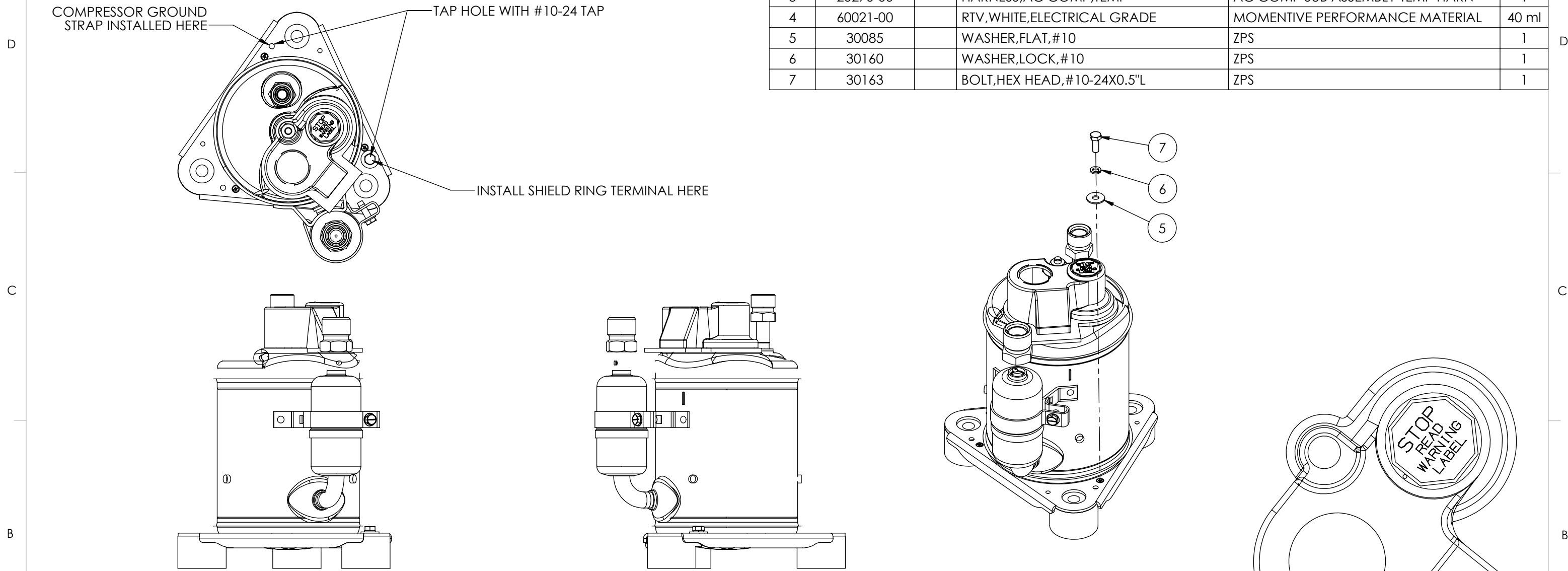

1. REMOVE BLACK COVER FROM COMPRESSOR
1. USING A 1" HOLE SAW DRILL A HOLE IN THE COVER
1. INSTALL COMPRESSOR WIRES ON COMPRESSOR ( A901 PHASE A, A903 PHASE B, A904 PHASE C)
1. INSTALL HARNESS 20070-XX ONTO TEMP SWITCH
1. ROUTE WIRES SO THEY EXIT OUT THE CHANNEL IN COVER
1. REINSTALL BLACK COVER
1. USING A #10-24 TAP, TAP OUT HOLE IN COMPRESSOR BASE
1. USING A #10-24X½" SCREW, #10 LOCK WASHER AND #10 WASHER, INSTALL SHIELD RING TERMINAL ONTO COMPRESSOR
1. USING RTV162 FILL THE CAVITY AROUND THE PHASE WIRES. BE SURE TO USE THE TIP OF THE RTV TUBE TO REMOVE THE AIR AND PUSH THE RTV DOWN INTO THE CAVITY
1. CHECK TO MAKE SURE RTV IS COMING OUT OF CHANNEL IN COVER
1. USING A WOODEN STICK SMOOTH THE TOP OF THE RTV EVEN WITH THE COVER
1. USE 3M SCOTCHKOTE TO COVER THE SHIELD TERMINAL AND SCREW ON COMPRESSOR BASE
1. ALLOW DRY TIME

PROPRIETARY AND CONFIDENTIAL  
 THE INFORMATION CONTAINED IN THIS DRAWING IS THE SOLE PROPERTY OF ODYNE SYSTEMS LLC.  
 REPRODUCTION IN PART OR AS A WHOLE WITHOUT THE WRITTEN PERMISSION OF ODYNE IS PROHIBITED.

UNLESS OTHERWISE SPECIFIED REFERENCE DIMENSIONS SHOWN IN PARENTHESIS DIMENSIONS ARE IN INCHES	DRAWN	AJC	01/09/14
	CHECKED	AJC	01/09/14
ANGULAR ± 1.0°	ENG APPR	AJC	1/9/2014
NOMINAL ± 0.050	MFG APPR	AJC	01/09/14
ONE PLACE DECIMAL ± 0.025	QA APPR		
TWO PLACE DECIMAL ± 0.010			
THREE PLACE DECIMAL ± 0.005			
MATERIAL	INTERPRET GEOMETRIC TOLERANCE PER ASME Y14.5M-1994		
FINISH			

**ODYNE**  
www.odyne.com

SUB-ASSY,AC,COMP W/POT HARNESS  
AC COMPRESSOR ASSM WITH HARNES

SIZE B	PART NUMBER 70187	REV 01
SCALE 1:3	DO NOT SCALE DRAWING	SHEET 1 OF 1